



LEADERS IN FLUID TRANSFER SOLUTIONS

AIR-OPERATED DOUBLE DIAPHRAGM PUMP USER'S MANUAL



WARNING: Read carefully and understand all INSTRUCTIONS before operating. Failure to follow the safety rules and other basic safety precautions may result in serious personal injury. Save these instructions in a safe place and on hand so that they can be read when required.

MODEL NUMBER: DITI17151201, DITI17150601V, DITI17150600N

AIR-OPERATED DOUBLE DIAPHRAGM PUMP USER'S MANUAL

MODEL NUMBER

DITI17151201, DITI17150601V,
DITI17150600N

B. OPERATING AND SAFETY PRECAUTIONS

READ, UNDERSTAND, AND FOLLOW THIS INFORMATION TO AVOID INJURY AND PROPERTY DAMAGE.



WARNING!

EXCESSIVE AIR PRESSURE. Can cause personal injury, pump damage or property damage.

- Do not exceed the maximum inlet air pressure as stated on the pump model plate.
- Be sure material hoses and other components are able to withstand fluid pressures developed by this pump. Check all hoses for damage or wear. Be certain dispensing device is clean and in proper working condition.



WARNING! STATIC SPARK. Can cause explosion resulting in severe injury or death. Ground pump and pumping system.

- Spark can ignite flammable material and vapors.
- The pumping system and object being sprayed must be grounded when it is pumping, flushing, recirculating or spraying flammable materials such as paints, solvents, lacquers etc. or used in a location where surrounding atmosphere is conducive to spontaneous combustion. Ground the dispensing valve or device, containers, hoses and any object to which material is being pumped.
- Use the pump grounding screw terminal provided. Connect a suitable ground wire to a good earth ground source.
- Secure pump, connections and all contact points to avoid vibration and generation of contact or static spark.
- Consult local building codes and electrical codes for specific grounding requirements.
- After grounding, periodically verify continuity of electrical path to ground. Test with an ohmmeter from each component (e.g., hoses, pump, clamps, container, spray gun, etc.) to ground to insure continuity. Ohmmeter should show 100 ohms or less.
- Use proper ventilation.
- Keep inflammables away from heat, open flames and sparks.
- Keep containers closed when not in use.



WARNING! Pump exhaust may contain contaminants. Can cause severe injury. Pipe exhaust away from work area and personnel.

- In the event of a diaphragm rupture material can be forced out of the air exhaust muffler.
- Pipe the exhaust to a safe remote location when pumping hazardous or inflammable materials.



WARNING! HAZARDOUS PRESSURE. Can result in serious injury or property damage. Do not service or clean pump, hoses or dispensing valve while the system is pressurized.



WARNING! EXPLOSION HAZARD. Models containing aluminum wetted parts cannot be used with III.

-Trichloroethane, Methylene Chloride or other Halogenated Hydrocarbon solvents which may react and explode.



CAUTION! Verify the chemical compatibility of the pump wetted parts and the substance being pumped, flushed or recirculated.



CAUTION! Do not use the pump for the structural support of the piping system. Be certain the system components are properly supported to prevent stress on the pump parts.



CAUTION! Prevent unnecessary damage to the pump. Do not allow pump to operate when out of material for long periods of time.

Disconnect air line from pump when system sits idle for long periods of time.

AIR-OPERATED DOUBLE DIAPHRAGM PUMP USER'S MANUAL

MODEL NUMBER
DITI17151201, DITI17150601V,
DITI17150600N

H. DIAGRAM & PARTS LIST

FLUID SECTION FOR MODEL: DITI17151201

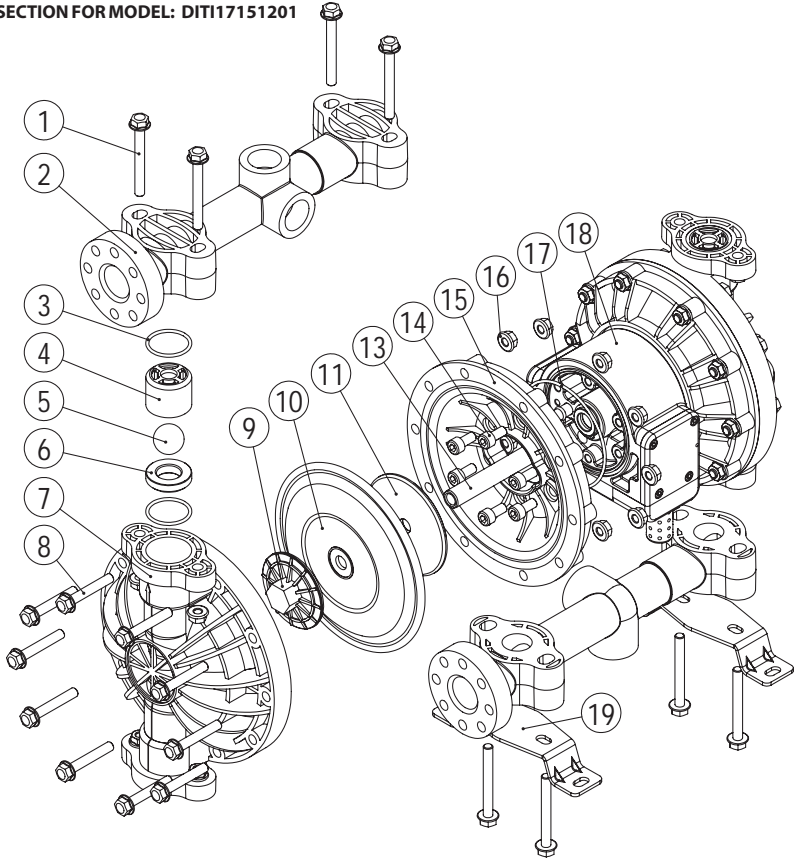

No.	Description	Qty.	No.	Description	Qty.
1	Hex-bolt M8x70	8	11	Air Chamber Plate	2
2	Discharge Manifold	2	13	Connecting Shaft	1
3	O-ring	8	14	Screw	12
4	Valve Cover	4	15	Air Chamber	2
5	Valve Ball	4	16	Screw	28
6	Valve Seat	4	17	O-ring	2
7	Liquid Chamber	2	18	Air Motor Assembly	1
8	Hex-bolt M8X50	20	19	Bracket	2
9	Liquid Chamber Plate	2			
10	Diaphragm	2			

AIR-OPERATED DOUBLE DIAPHRAGM PUMP USER'S MANUAL

MODEL NUMBER
DITI17151201, DITI17150601V,
DITI17150600N

H. DIAGRAM & PARTS LIST

FLUID SECTION FOR MODEL: DITI17150600N

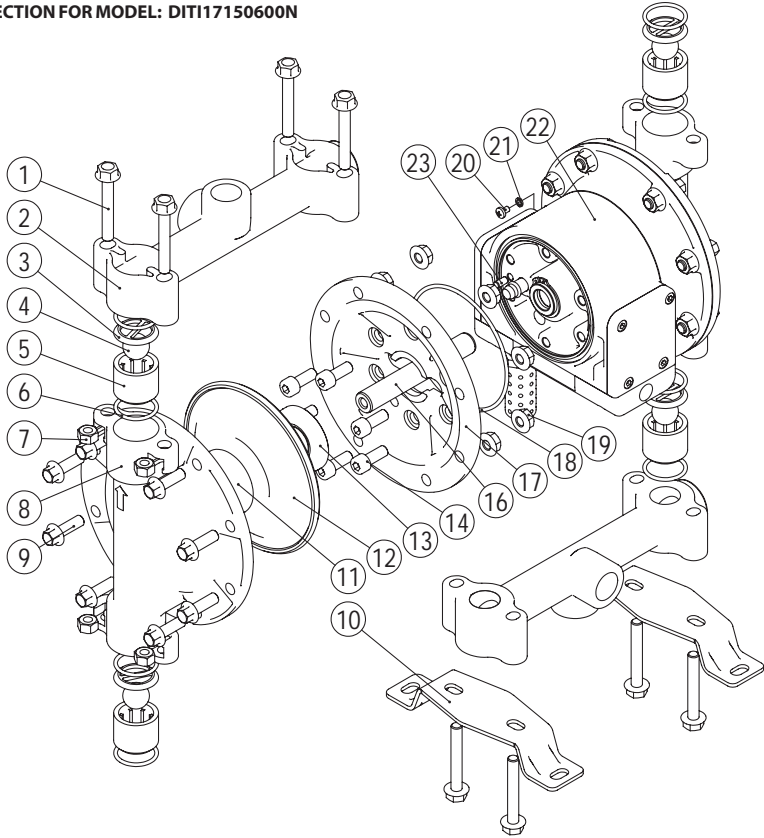

No.	Description	Qty.	No.	Description	Qty.
1	Hex-bolt M8x55	8	12	Diaphragm	2
2	Discharge Manifold	2	13	Air Chamber Plate	2
3	Valve cover	4	14	Screw M8X16	12
4	Valve Ball	4	16	Connecting Shaft	1
5	Valve Seat	4	17	Air Chamber	2
6	O-ring 28.24x2.62	8	18	O-ring 94.92X2.62	2
7	Nut M8	8	19	Hex-bolt M8	16
8	Liquid Chamber	2	20	Screw M5X8	1
9	Hex-bolt M8X25	16	21	Washer	1
10	Bracket	2	22	Air Motor Assembly	1
11	Liquid Chamber Plate	2	23	straight pin	2

AIR-OPERATED DOUBLE DIAPHRAGM PUMP USER'S MANUAL

MODEL NUMBER
DITI17151201, DITI17150601V,
DITI17150600N

J. DIMENSIONAL DATA

